

# DAR-320H-VDX

1/3" Sony Super HAD CCD, with Digital Noise Reduction . Easy Adjustment with 3D Axis Bracket, 20m IR Projection Distance, IP66 Vandal Proof Design

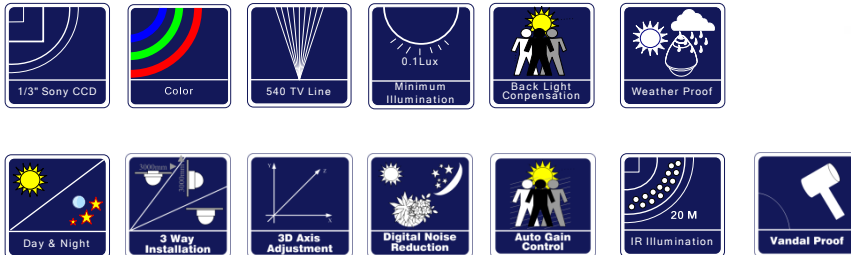

## Specification

System	NTSC / PAL
Pick-up Device	1/3" Sony Super HAD <sup>®</sup> CCD
Active Picture Elements	NTSC: 768(H) x 508(V) / PAL: 752(H) x 582(V)
Synchronization System	Internal / Line Lock (Dip switch adjust)
Gamma Correct	0.45
Horizontal Resolution	540 TV Line (Color)
White Balance	Auto Trace White Balance(2500K ~ 9500K)/AWB
Electric Shutter	Auto: NTSC 1/60 ~ 1/10K s; PAL: 1/50 ~100k s
S/N Ratio	More than 50 DB (AGC Off)
Auto Gain Control (AGC)	On (36dB) / Off
Minimum Illumination	IR LED OFF: 0.1Lux (F 1.2 AGC on, 30 IRE); 0.001Lux (F1.2 AGC on, B/W mode, sense up on); IR LED on: 0 Lux
Illumination	35x LED Wave Length @ 780nm ~ 1100nm
Video Color	On / Off (Dip Switch Adjust)
Back Light Compensation (BLC)	On /Off (Dip Switch Adjust)
Video Output	BNC composite: 1.0 Vp-p / 75 ohms
Lens	3.7mm ~ 12mm, optional other size
External Adjustment	Level Control
Internal Adjustment	H Mirror: ON / OFF; V Mirror: ON / OFF; , Day/Night Control: ON /OFF
External Connection	Video( BNC), DC 12V / AC 24VInput
Current	450mA (max) DC 12V
Power Supply	DC 12V / AC 24V
Power Consumption	5.4 W max.
Operation Temperature	-10°C ~ +50°C

## Digital Noise Reduction

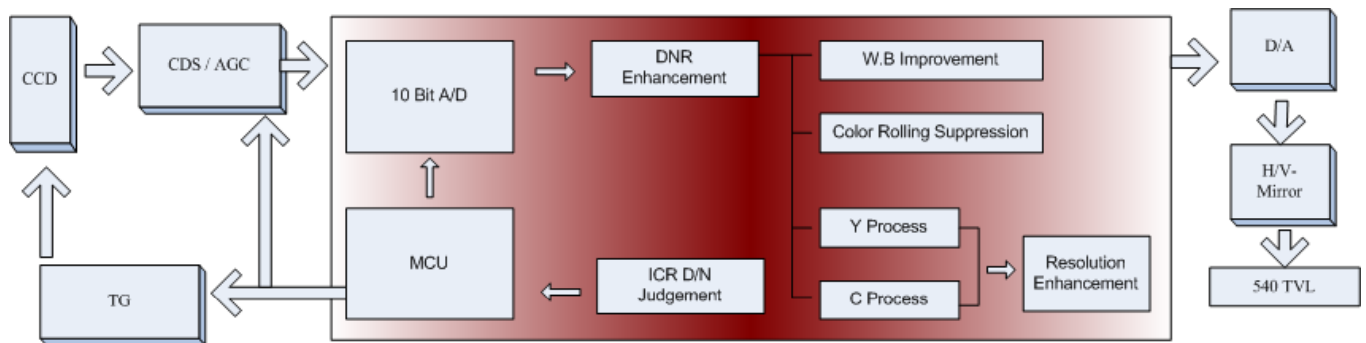

DNR is a new technology to suppress all significant noise when AGC(Auto Gain Control) is activated. DNR allows camera to smooth and evenly noised image. This will increase the recognition of the image. Beside it will help to save the video transmission traffic when connected with DVR or Video Server.



**DNR**



**Traditional  
AGC**

## Sense UP

Sense up is a function to improve the ability to achieving higher sensitivity. It is an extra aid for seeing better in black. With the setting of sense up on, it will achieve B/W image at extreme low lux 0.001 at F 1.2.



**Sense Up  
Off**



**Sense Up  
On**

## Day / Night OLPF

Ordinary IR cut filter will cause the focus shifting while IR on and Off. Specially designed Optical Low Pass Filter (OLPF) enable the device to switch on and off precisely. It will help to deliver the live image with true color during the day and focus correctly while IR is on during the night.

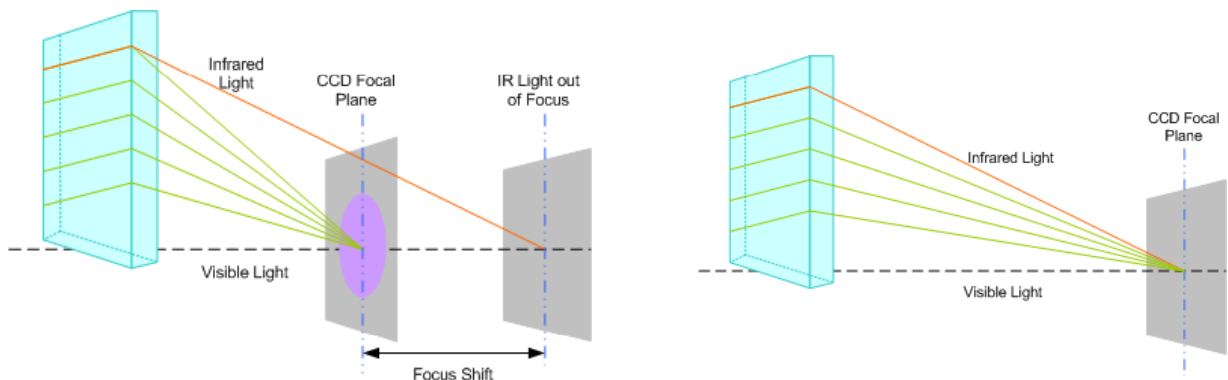

## Extra Control Board

Side control board design make the camera setting and adjustment easier. The other RCA connector enable the camera to connect to the test monitor during the installation

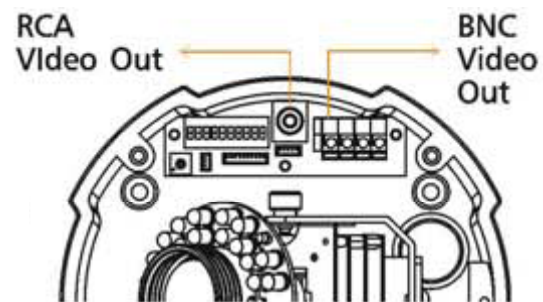

## Dimension

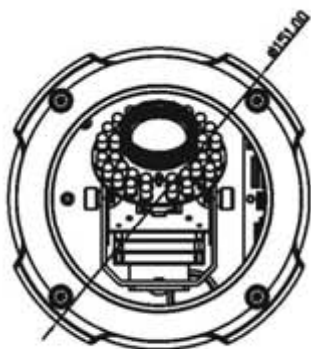

## Installation

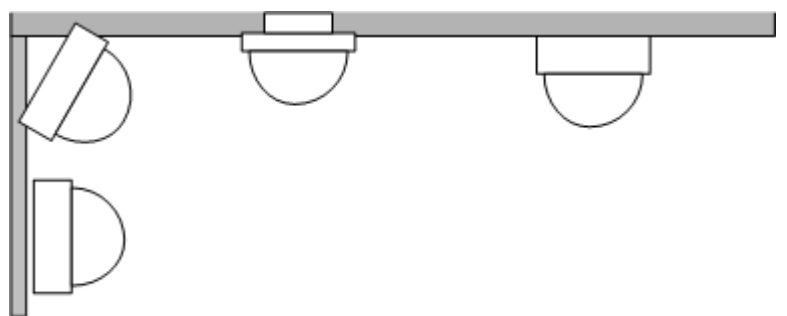

## Model Selection

DAR-320H-VDXP: DC 12V / AC 24V, PAL

DAR-320H-VDXN: DC 12V/ AC 24V , NTSC