

# DAR-430-V

1/3" Sony Super HAD CCD, with Digital Noise Reduction . 40m IR Projection Distance, IP66 Weather Proof Design, External Lens Adjustment and IR Distance Adjustment

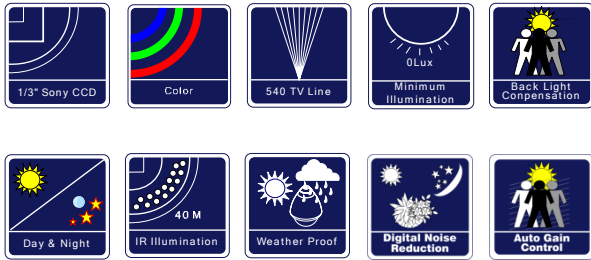

## Specification

System	NTSC / PAL
Pick-up Device	1/3" Sony Inter-line Transfer Super HAD® CCD
Active Picture Elements	NTSC: 768(H) x 508(V) / PAL: 752(H) x 582(V)
Synchronization System	Internal / Line Lock
Gamma Correct	0.45
Minimum Illumination	0.1 Lux at F1.2, 0.001 Lux F 1.2( B/W mode wi/ Sense up), 0 Lux with IR on
Horizontal Resolution	420 TV Line (Color)
White Balance	Auto Trace White Balance(2500K ~ 9500K)/AWB
Electric Shutter	Auto: NTSC 1/60 ~ 1/10K s; PAL: 1/50 ~100k s
S/N Ratio	More than 50 DB (AGC Off)
Auto Gain Control (AGC)	On (36dB) / Off
Illumination	18x Ø5mmLED 12X Ø8mm LED, Wave Length @ 780nm ~ 1100nm
Back Light Compensation (BLC)	On /Off (Dip Switch Adjust)
Video Output	BNC composite: 1.0 Vp-p / 75 ohms
Lens	3.0mm ~ 12mm
External Adjustment	Level Control
Internal Adjustment	H Mirror: ON / OFF; V Mirror: ON / OFF; , Day/Night Control: ON /OFF
External Connection	Video( BNC), DC 12V / AC 24VInput
Current	700mA (max)
Power Supply	DC 12V / AC 24V
Power Consumption	5.4 W max.
Operation Temperature	-10°C ~ +50°C

## Digital Noise Reduction

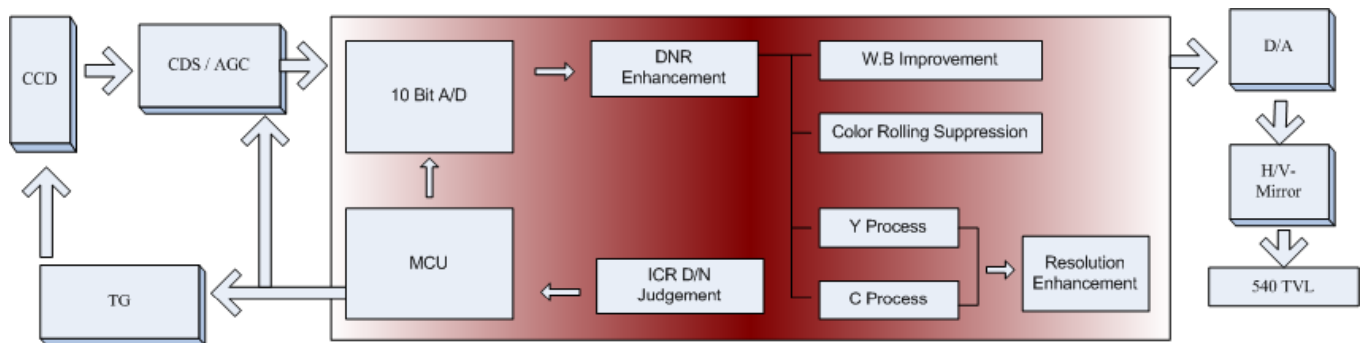

DNR is a new technology to suppress all significant noise when AGC(Auto Gain Control) is activated. DNR allows camera to smooth and evenly noised image. This will increase the recognition of the image. Beside it will help to save the video transmission traffic when connected with DVR or Video Server.



**DNR**



**Traditional  
AGC**

## Sense UP

Sense up is a function to improve the ability to achieving higher sensitivity. It is an extra aid for seeing better in black. With the setting of sense up on, it will achieve B/W image at extreme low lux 0.001 at F 1.2.



**Sense Up  
Off**



**Sense Up  
On**

## Day / Night OLPF

Ordinary IR cut filter will cause the focus shifting while IR on and Off. Specially designed Optical Low Pass Filter (OLPF) enable the device to switch on and off precisely. It will help to deliver the live image with true color during the day and focus correctly while IR is on during the night.

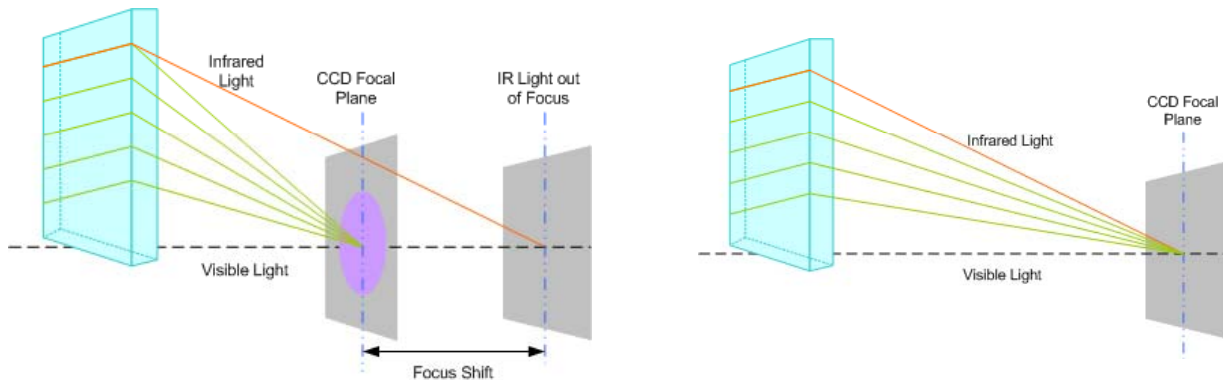

## Adjustable IR Angel

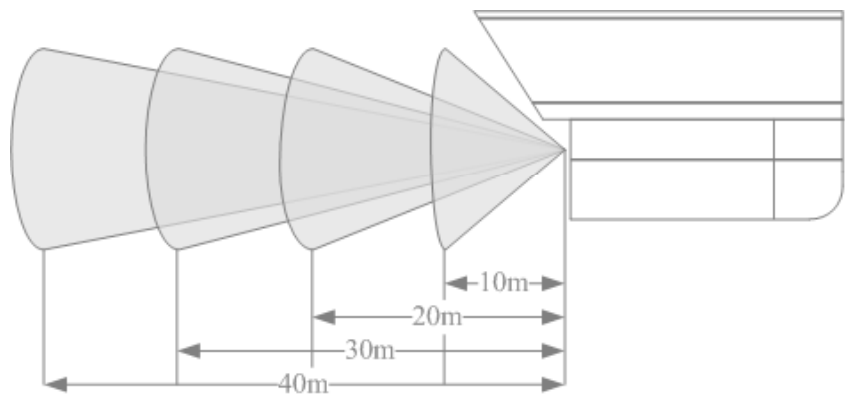
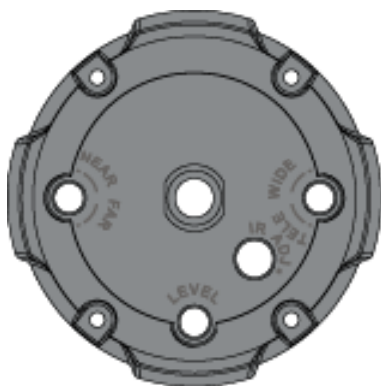

## Dimension

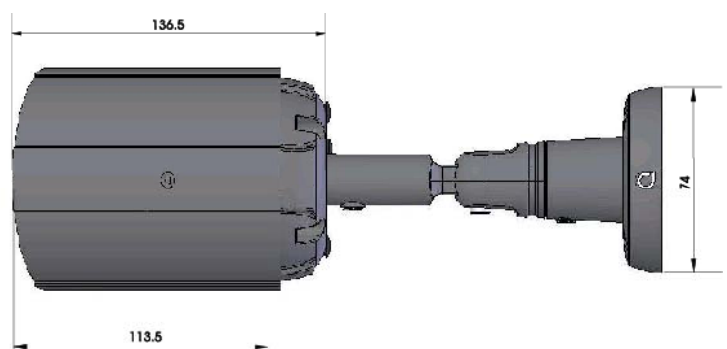
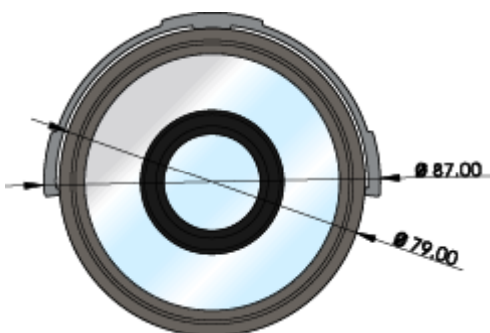

## Model Selection

DAR-430H-VP: 540TVL DC 12V / AC 24V, PAL    DAR-430H-VN: 540TVL DC 12V/ AC 24V, NTSC

DAR-430-VP: 420 TVL, DC12V/ AC24V, PAL    DAR-430-VN: 420TVL, DC12V/ AC24V, NTSC